

## Operating Manual

---

### Water separator / Fuel pre-filter SWK

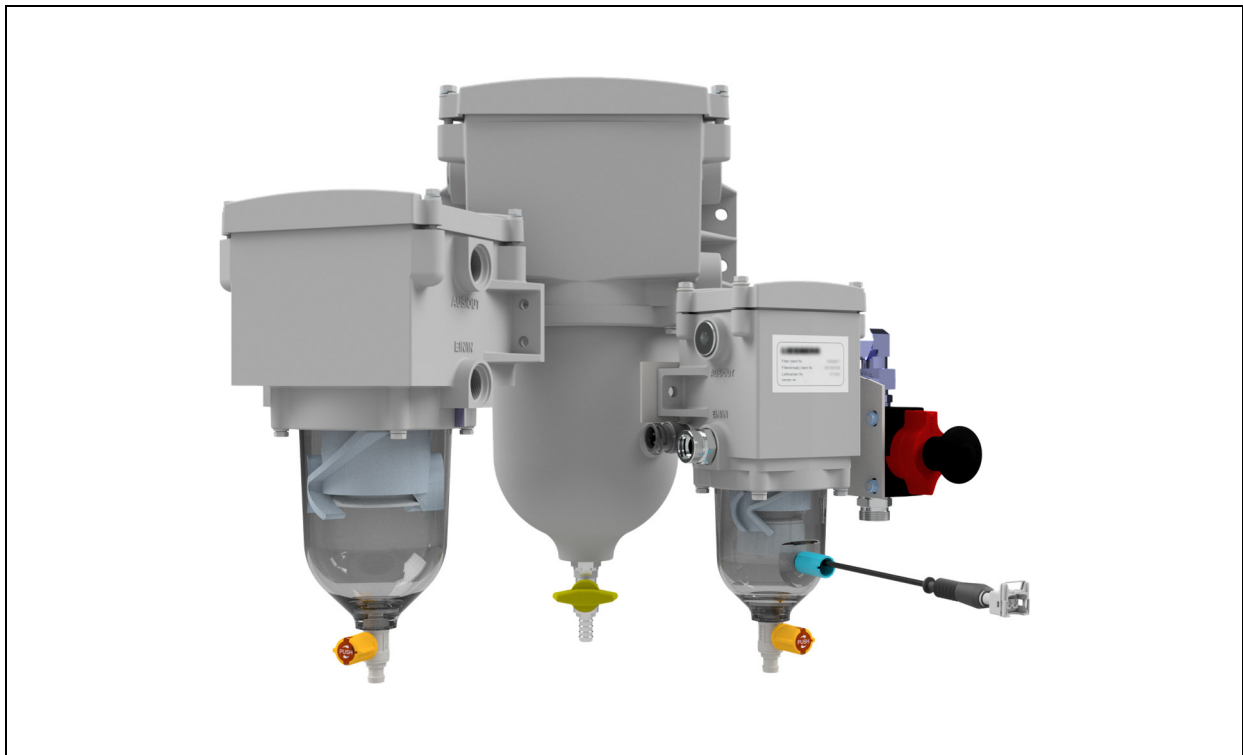



## Table of contents

<b>General information.....</b>	<b>4</b>
1.1 Disclaimer.....	4
1.2 Symbols used .....	4
1.3 Safety instructions.....	4
1.4 Intended use .....	5
<b>2 Introduction.....</b>	<b>6</b>
2.1 Why Separ .....	6
2.2 Function of the SWK.....	6
2.3 Fields of application of the filter .....	7
2.4 Tests and Certificates .....	8
<b>3 Delivery .....</b>	<b>9</b>
3.1 Scope of delivery.....	9
3.2 Unpacking.....	9
3.3 Storage .....	9
<b>4 Technical description .....</b>	<b>10</b>
4.1 General arrangement drawing.....	10
4.2 Dimensions and weights .....	12
4.3 Characteristics.....	12
4.4 Available options.....	13
4.5 Materials used.....	14
4.6 Electrical data.....	14
4.7 Mechanical connections .....	14
4.8 Temperature ranges.....	14
<b>5 Filter combinations .....</b>	<b>14</b>
5.1 Switch-over system .....	15
5.2 Double-unit system .....	17
<b>6 Options.....</b>	<b>18</b>
6.1 Filter heating .....	18
6.1.1 Heating system SWK-5/50, /10 and /18.....	18
6.1.2 Fuel pre heating system SWK-40/MH or MHS.....	19
6.2 Water in fuel sensor (WIF) .....	23
6.3 Differential pressure switch .....	23
6.4 Relative pressure switch .....	23
6.5 Vacuum gauge.....	23
6.6 Bowl.....	24



<b>7</b>	<b>Assembly</b> .....	<b>25</b>
7.1	Selection of mounting position .....	25
7.2	Filter installation .....	25
7.3	Electrical connection .....	26
7.4	Disassembly .....	26
<b>8</b>	<b>Commissioning</b> .....	<b>27</b>
<b>9</b>	<b>Maintenance</b> .....	<b>28</b>
9.1	Tightening torques .....	28
9.2	Drainage of water .....	28
9.2.1	Handling of the ball valve .....	29
9.3	Back-flushing process .....	31
9.4	Element replacement .....	33
9.5	Cleaning .....	34
<b>10</b>	<b>Repair</b> .....	<b>34</b>
<b>11</b>	<b>Accessories</b> .....	<b>35</b>
<b>12</b>	<b>Disposal</b> .....	<b>36</b>
<b>13</b>	<b>Annex A: Special versions</b> .....	<b>37</b>
13.1	Drainage of water .....	37
13.2	Dimensions and weights .....	38
13.3	Characteristics .....	38
<b>14</b>	<b>Annex B: Specific drawings</b> .....	<b>38</b>

## 1 General information

### 1.1 Disclaimer

The preparation of this document was made as carefully as possible. However, errors can not be excluded. Therefore, we do not take over any liability for errors or deficits in this document, nor for any consequential damages which may arise there from.

We reserve the right to make technical changes to this document or the product described herein without notice.

### 1.2 Symbols used

The following symbols are used in this document to visually emphasize important information and warnings:



**Note**

*Note on special tips and other helpful or important information.*



**Attention**

*Disregarding these instructions may damage the fuel filter or the machine where the filter is mounted.*



**Disposal**

*Note on special measures for protection of the environment / surroundings and disposal of the system or parts of the system.*

### 1.3 Safety instructions



**Wear goggles**



**Wear protective gloves**



**Ventilate the work area**



**Refrain from smoking**



**No open fire**



**No food in the work area**

Works on the system have to be performed by trained personal only and in compliance with the applicable work safety regulations. Generally operate on a cut-off, voltage-free system.



The filter may be under pressure. Therefore never open a filter in operation, otherwise fuel may leak into the environment and the engine draws air, which can cause damage to the engine.

When using duplex or switchable filters, the lever position indicates which filter is in operation. At this moment the other filter is isolated from the fuel circuit, but still could contain fuel.

Filters with fuel pre heating systems may only be placed in operation when completely filled with fuel and primed of air.

The electrical current for the heater must never be turned on without grounding and activated associated control system.

Remove spilled fuel immediately and dispose them in accordance with the applicable statutory provisions (s. cha. 12).

## 1.4 Intended use

The filter is intended for the filtration of diesel fuels and mineral oils with a dynamic viscosity < 10 mPas, flash point > 55 °C and boiling point > 160 °C and is designed for operation in between fuel tank and fuel lift pump (suction side). The filter should never be installed on the pressure side, behind the fuel pump.



## 2 Introduction

### 2.1 Why Separ

In 1992, the generation SWK water separators / fuel filter was developed by the company W. Lösing Filterproduktion GmbH as an effective system for the separation of water and dirt particles which are contained in the fuel. Both water and dirt can lead to high wear and tear on engines as well as the injection systems and result in expensive, intensive repairs and equipment down time.

SWK offers:

- Smallest and most compact design
- High separation efficiency
- Low flow resistance
- Long life filter element
- Easy installation
- Simple maintenance
- Different flow rates
- Minimal maintenance effort
- Environment friendly

### 2.2 Function of the SWK

The separation and purification process using a special patented system that is used throughout all of the different sizes, which stick out through most compact design in relation to the effective flow rate.

Generally, the SWK is installed on the vacuum side of the fuel system, i. e. between fuel tank and fuel pump.

The fuel enters the filter through one of the two inlet parts, the unused port must be sealed off with the attached plug.

#### Stage 1

From the inlet port, fuel flows into the filter and passes an interior vane system whereby the fuel is moved in an intensive circular motion.

#### Stage 2

The centrifugal gravity, resulting from the circular motion, forces the fuel to the outer wall of the bowl. The heavier water droplets and heavier particles collect on the wall of the bowl and settle due to natural gravity to the bottom of the bowl.

## Stage 3

In the further flow the fuel passes the outer vane system. By the different length of the vanes and the twofold change in the fuel flow direction, smaller water droplets and fine dirt particles settle on the vanes, where they agglomerate and then decline, caused by gravity, down to the bottom of the bowl. Already at this point the major portion of any contaminants in the fuel have been separated.

## Stage 4

Below the filter element, on the so-called dome, the flow cross-section is considerably increased, whereby a slow-down of the fuel occurs. This also allows smallest water droplets and dirt particles to settle. Through the previous pre-separation, the majority of the contamination (water and dirt) settles in the bowl and prolongs significantly the lifetime of the filter element.

## Stage 5

The remaining suspended contamination in the fuel, finest water droplets and smallest particulates are filtered by a replaceable filter element which is produced from a special cellulose paper or stainless steel mesh elements.

The clean fuel leaves the filter through one of the outlet ports (the port not required should be sealed off with the plug attached) and continues through the fuel system.

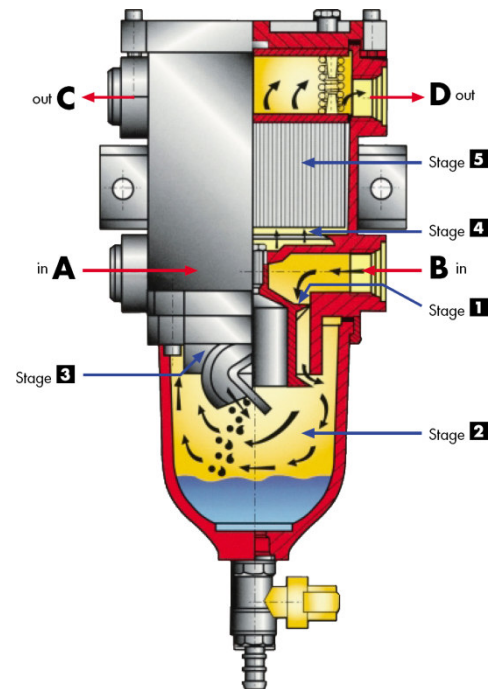

## 2.3 Fields of application of the filter

- Vehicle industry – trucks, busses, crane trucks, municipal vehicles, etc.
- Construction machinery, agricultural machinery, forklifts, compressors, etc.
- Ship propulsion motors, auxiliary units
- Stationary engines and generators, welding and pumping units
- Mining machinery, rail vehicles



There are also versions available for special applications.

Specifically for marine or prime power application duplex or switchable filters are offered. Thereby a filter can always be serviced, while the other filter is under flow without engine shut down.

For engines burning biodiesel appropriate versions are available.

For winter operation the SWK filter is available with pre-heating systems.

For hot environments there are custom high-temperature variants available.

## 2.4 Tests and Certificates

The SWK has various approvals and certificates. Copies can be provided on request. Below is a list of organizations that have carried out these tests.

- Rheinisch-Westfälischer TÜV
- KBA - Kraftfahrt-Bundesamt Flensburg
- German Technical Department for Army Ship and Marine Weapons
- GL - Germanischer Lloyd Type Approval Certificate
- Bureau Veritas Type Approval Certificate
- RINA
- ABS – American Board of Shipping
- LR – Lloyds Registry London
- Gost Standard
- Fire Resistance Test by MPA – Material Prüfungsamt NRW

## 3 Delivery

### 3.1 Scope of delivery

Check if you have the following accessories:

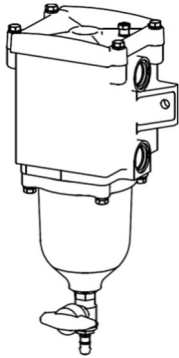

Filter assembly  
(s. chap. 4.1)

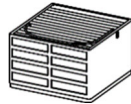

Filter element  
(already installed)



2 plugs

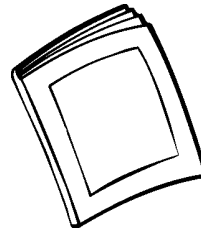

Operating instruction

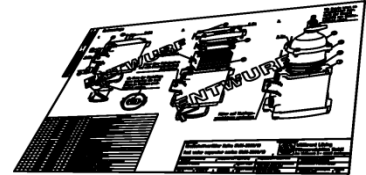

specific drawings  
(upon request)

### 3.2 Unpacking

Before opening check the delivery for outer damage. Report any damage to carrier.



**DISPOSAL**

*Please follow the environmental guidelines and laws of your country. Make sure the packaging material is disposed according to applicable regulations.*

### 3.3 Storage

The filter and its accessories must be kept dry and in compliance with the maximum permitted temperature ranges (s. chap. 4.8).

During a long storage period you should close all openings on the filter in order to protect the interior and the filter element from unnecessary pollution. All filters out of the factory have all ports sealed with plastic plugs.

## 4 Technical description

### 4.1 General arrangement drawing

Using the example of the SWK-10:

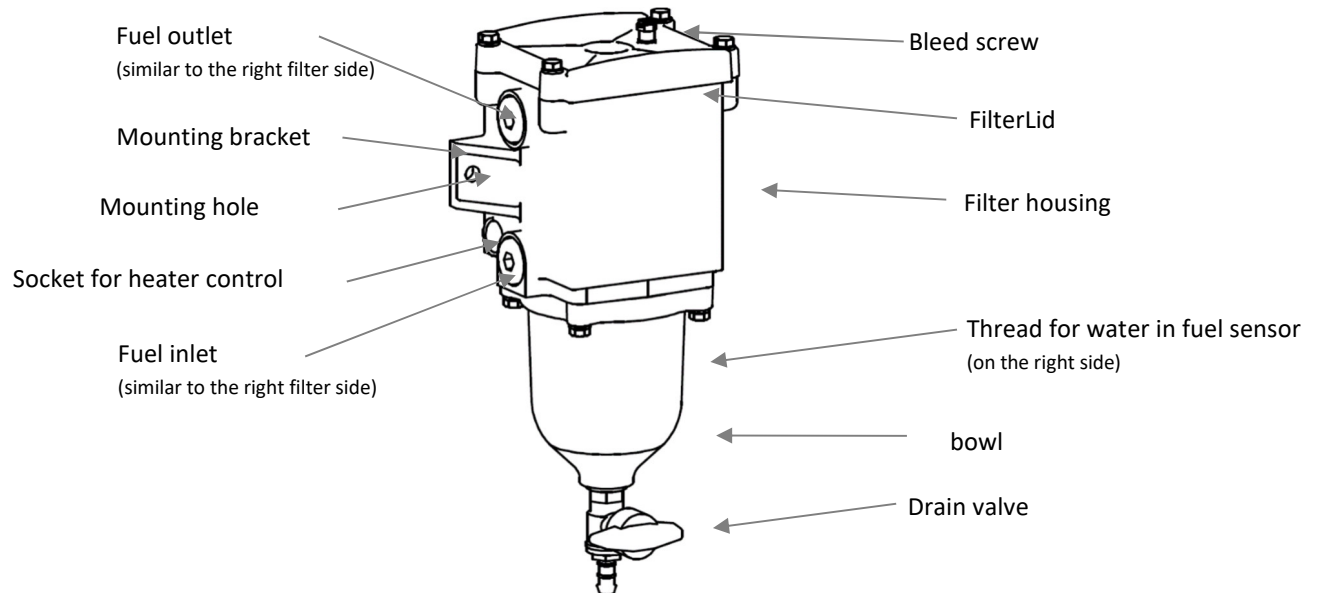

Using the example of the SWK-40/M/H:

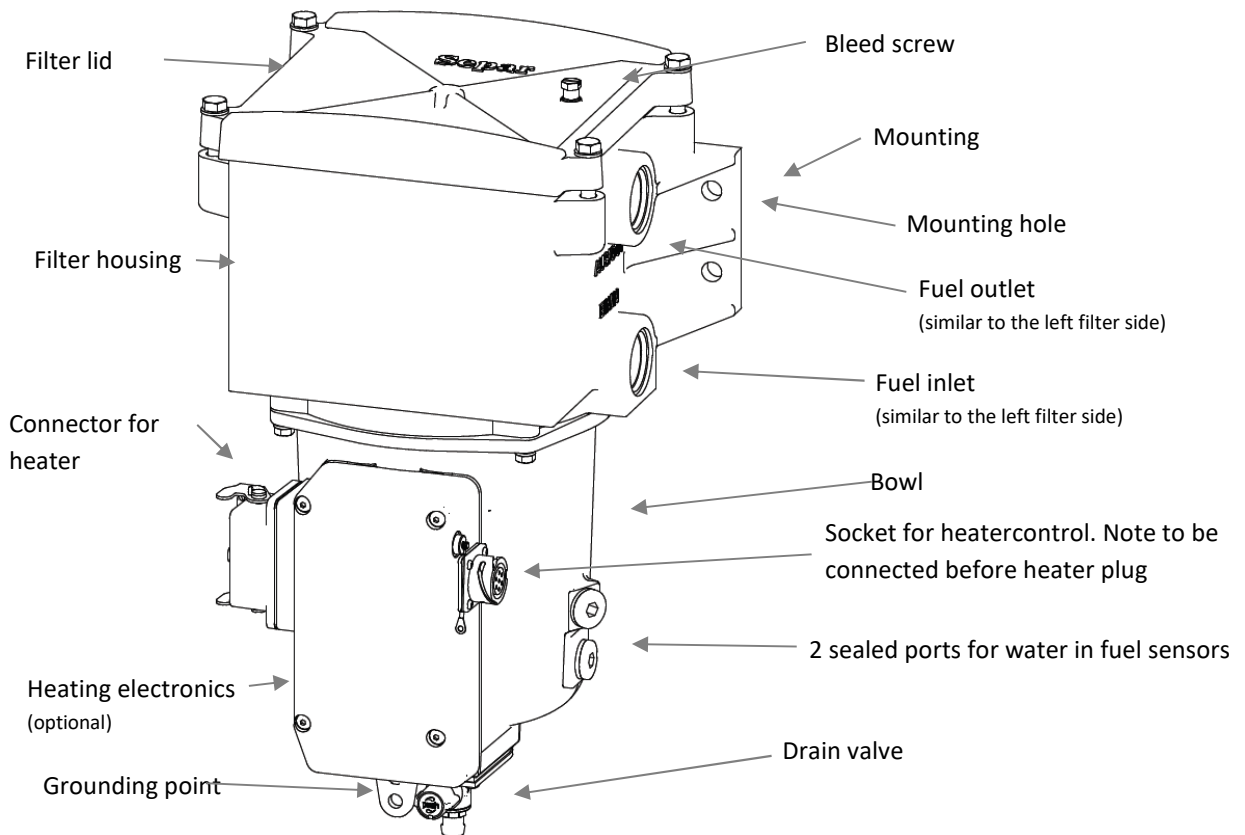

Example of a filter element:

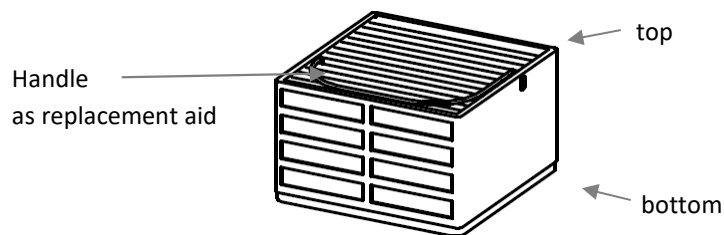

The filter shown here may differ from your purchased filter. The actual appearance and arrangement of the components depends on the configuration of the filter you have chosen.

## 4.2 Dimensions and weights

	SWK-5	SWK-5/50	SWK-10	SWK-18	SWK-40	SWK-130
Width	140 mm /WSA: 210 mm	140 mm	150 mm /WSA: 220 mm	210 mm	290 mm	420 mm
Hight	275 mm	310 mm	340 mm	410 mm	470 mm	720 mm
Depth	90 mm	90 mm	110 mm	165 mm	250 mm	370 mm
Weight	< 2,5 kg	< 2,7 kg	< 3 kg	< 8 kg	< 15 kg	< 55 kg
Mountig holes	2 x $\varnothing$ 9 mm	2 x $\varnothing$ 9 mm	2 x $\varnothing$ 9 mm	4 x $\varnothing$ 9 mm	4 x $\varnothing$ 12 mm	8 x $\varnothing$ 15 mm
The dimensions of filter combinations may differ (see Chapter 5)						

## 4.3 Characteristics

	SWK-5	SWK-5/50	SWK-10	SWK-18	SWK-40	SWK-130
Flow performance	5 l/min	5 l/min	10 l/min	18 l/min	40 l/min	130 l/min
Complete interior volume	450 $\pm$ 30 ml	700 $\pm$ 35 ml	1200 $\pm$ 50ml	3100 $\pm$ 90ml	7000 $\pm$ 200 ml	40 $\pm$ 1 l
Water-holding capacity	120 $\pm$ 10 ml	120 $\pm$ 10 ml	240 $\pm$ 20 ml	500 $\pm$ 30 ml	1500 $\pm$ 50 ml	8,5 $\pm$ 0,5 l
Alarm on water quantity	80 $\pm$ 10 ml	80 $\pm$ 10 ml	140 $\pm$ 20 ml	300 $\pm$ 30 ml	1250 $\pm$ 50 ml	7 $\pm$ 0,5 l
Water-holding capacity with heater	-	100 $\pm$ 10 ml	200 $\pm$ 20 ml	450 $\pm$ 30 ml	1100 $\pm$ 50 ml	-
Alarm on water quantity (with heater)	-	70 $\pm$ 10 ml	140 $\pm$ 20 ml	300 $\pm$ 30 ml	1) 350 $\pm$ 50 ml 2) 950 $\pm$ 50 ml	-
Maximum allowable operating pressure	0,5 bar					
Burst pressure	15 bar	15 bar	12 bar	7 bar	4 bar	2 bar
Water separation	> 99 % des freien Wassers <sup>1</sup>					
Available filter units	10 $\mu$ m (coated cellulose paper) 30 $\mu$ m (coated cellulose paper) 30 $\mu$ m (stainless steel mesh) 60 $\mu$ m (stainless steel mesh)					
The characteristics of filter combinations may differ (see Chapter 5)						

<sup>1</sup> The water separation was detected at W. Lösing Filterproduktion GmbH based on the DIN 4020 and the ISO-TS 16332.

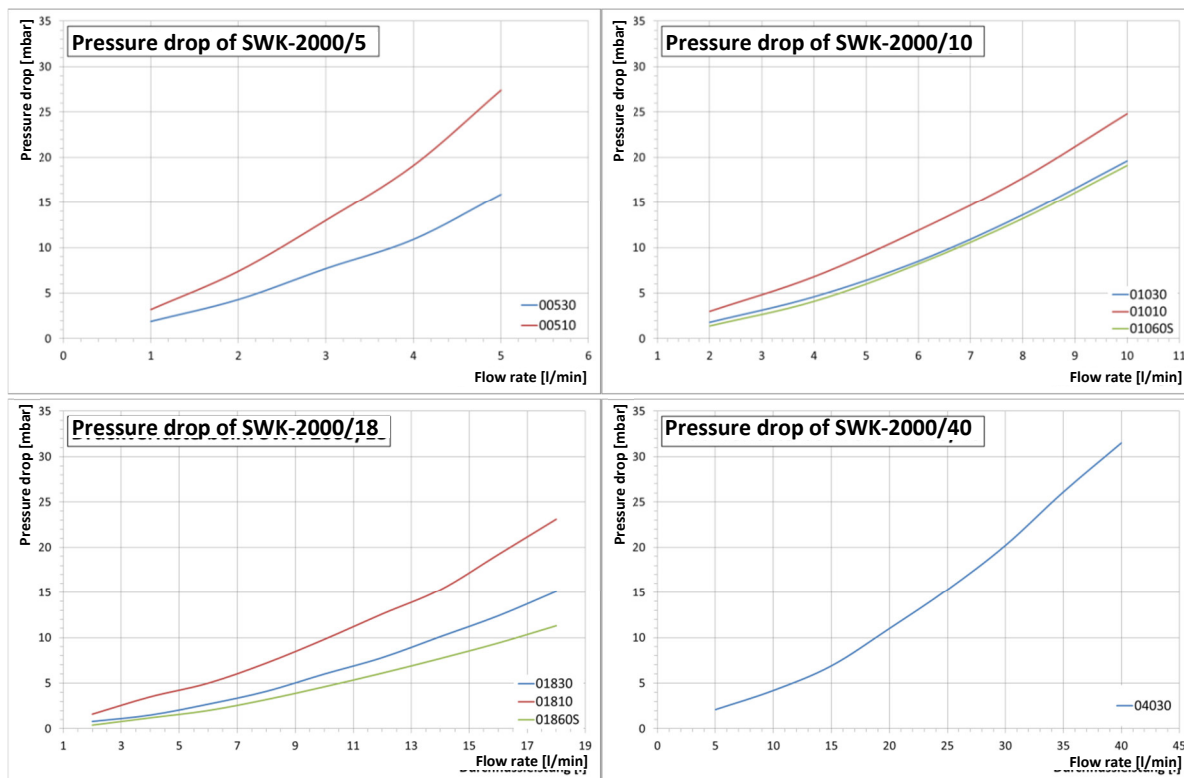

Pressure drop<sup>2</sup>

#### 4.4 Available options

	SWK-5	SWK-10	SWK-18	SWK-40	SWK-130
heating	x <sup>3</sup>	X	X	X	-
Water sensor	X	X	X	X	X
Relative pressure switch	X	X	X	X	X
Differential pressure switch	X	X	X	X	X
Clogging indicator	X	X	X	X	X
Transp. bowl	X	X	X	-	-
Metal bowl	X	X	X	X	X
Heavy-Duty design	X	Not applicable because only Heavy-Duty version available.			

<sup>2</sup> All pressure losses were measured with diesel according to EN590 at 20 °C ± 2 °C fuel and ambient temperature.

<sup>3</sup> Only in connection with option /50

## 4.5 Materials used

Filter cover, filter housing	Aluminium
Bowl	Aluminium or transparent PA
Drain valve	Brass, PBT
Gaskets	TPE and/or HNBR
Bleed screw	Steel
Outboard screws	Stainless steel A2

## 4.6 Electrical data

Electrical components are installed only in conjunction with a filter heater, water in fuel sensor and/or pressure switch. The electrical data on these options please refer to chapters 6.1 and 0. Filter sizes for which the above options are available please refer to chapter 4.4.

## 4.7 Mechanical connections

	SWK-5	SWK-10	SWK-18	SWK-40	SWK-130
Fuel inlet	M16x1,5	M22x1,5	M26x1,5	M33x2	G2"
Fuel outlet	M16x1,5	M22x1,5	M26x1,5	M33x2	G2"
Recommended minimum-diameter performance	8 mm	12 mm	20 mm	26 mm	40 mm
The dimensions of filter combinations may differ (see Chapter 5)					

Adapter for the fuel inlet and fuel outlet can be obtained as an accessory through the W. Lösing Filtertechnik e. K..

## 4.8 Temperature ranges

Filters are designed to operate in temperature range of -40 °C to 80 °C.

On the filter with fuel pre heating system, selected thermal fuses are installed. Fuses will be irrevocably destroyed when ignoring the stated temperature limit.

## 5 Filter combinations

In some areas of application it may be necessary to combine two structurally identical filters with one another. Currently, two different combination options are offered.

## 5.1 Switch-over system

A switch-over system (marked in the product key through the addition /U) is a redundant Separ filter structure. The redundant system ensures uninterrupted operation of the filter system (e.g. during maintenance work on the filter).

Example of a switch-over system<sup>4</sup>:

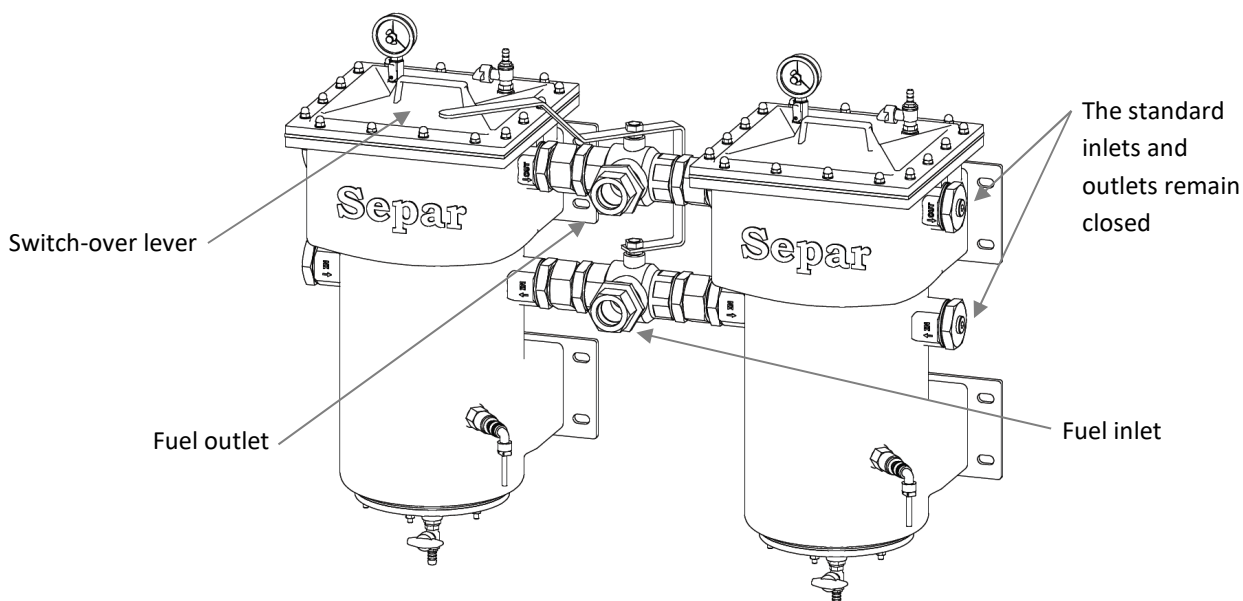

Both filters have a common fuel inlet and a common fuel outlet. Using the switch-over lever, the filter through which the fuel should pass can be changed. The other respective filter is now no longer part of the fuel circulation and can be emptied and opened for maintenance purposes (see Chapter 9). Operation of the switch-over system in other lever positions to those shown in the following diagram is not permitted (move the lever only to the right or to the left as far as it will go)!

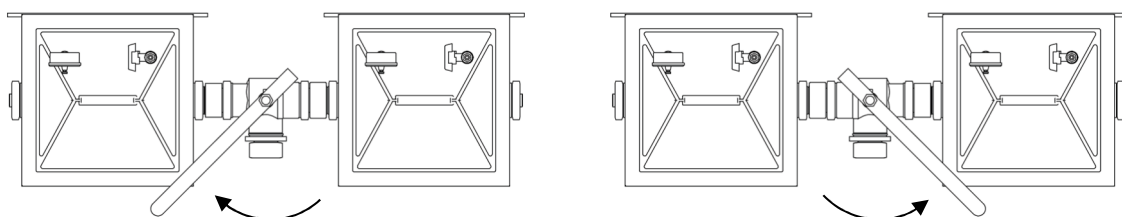

Left filter is active

Right filter is active

<sup>4</sup> Example includes special options

Deviations to Chapter 4.2 Dimensions and weights						
	SWK-5/U	SWK-5/50/U	SWK-10/U	SWK-18/U	SWK-40/U	SWK-130/U
Width [mm]	440	440	460	630	800	1,100
Height [mm]	300	340	380	450	530	860
Depth [mm]	160	160	200	230	280	430
Weight [kg]	< 8	< 8	< 10	< 20	< 40	< 120
Fixing holes [mm]	2x slotted holes (18x9) Distance apart: 416	2x slotted holes (18x9) Distance apart: 416	4x slotted holes (18x9) Distance apart: 435x85	4x slotted holes (24x12) Distance apart: 590x80	4x slotted holes (24x12) Distance apart: 760x100	16x slotted holes (27x15) Distance apart: See drawings
All sizes and weights may vary according to the precise configuration of the filter assembly. The exact dimensions should be taken from the specific drawing of your filter.						

The performance characteristics from Chapter 4.3 retain their validity for each individual filter.

Deviations to Chapter 4.7 Mechanical connections					
	SWK-5/U	SWK-10/U	SWK-18/U	SWK-40/U	SWK-130/U
Fuel inlet and outlet	Union nut with a cutting ring for a pipe with an external diameter of				G2"
	12 mm	15 mm	22 mm	35 mm	

## 5.2 Double-unit system

In the case of a double-unit system, two identical filters are installed parallel in the fuel circulation. By parallelising the filter, the double-unit system is able to achieve twice the flow rate as that of a single filter.

Example of a double-unit filter system<sup>4</sup>:

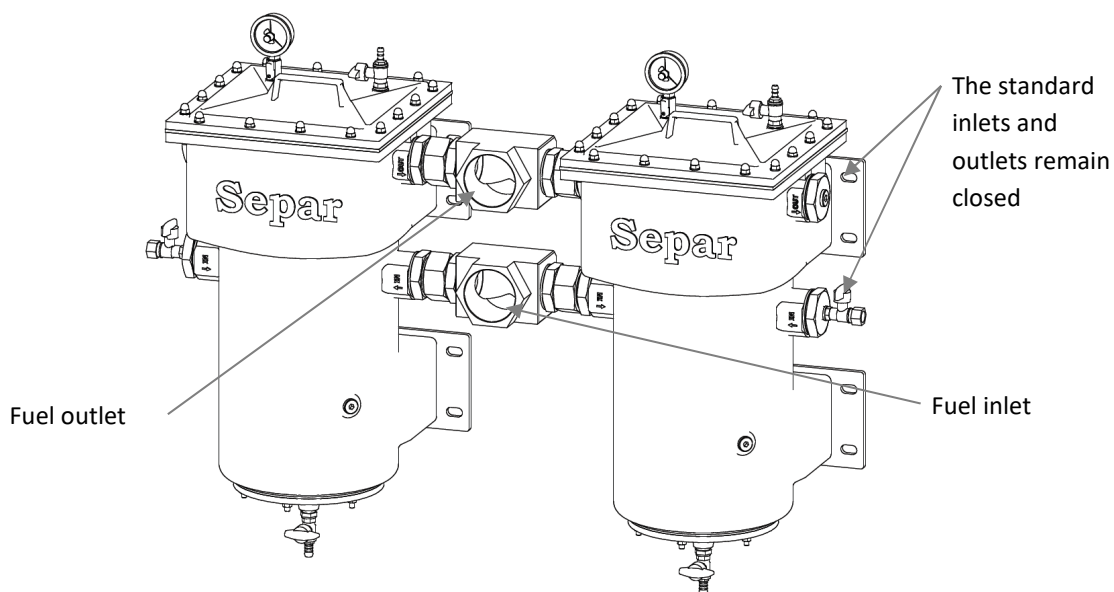

Deviations to Chapter 4.2 Dimensions and weights		
	SWK-40/2	SWK-130/2
Width [mm]	870	1.100
Height [mm]	480	860
Depth [mm]	240	370
Weight [kg]	< 35	< 120
Fixing holes [mm]	4x slotted holes (24x12) Distance apart: 835x100	16x slotted holes (27x15) Distance apart: See drawings
All sizes and weights may vary according to the precise configuration of the filter assembly. The exact dimensions should be taken from the specific drawing of your filter.		

<sup>4</sup> Example includes special options

Deviations to Chapter 4.3 Characteristics		
	SWK-40/2	SWK-130/2
Flow rate	80 l/min	260 l/min
Total interior volume	14 ± 0.2 l	80 ± 1 l
Water absorption capacity	3 ± 0.05 l	17 ± 0.5 l
Water volume alarm	2.5 ± 0.05 l	14 ± 0.5 l

Deviations to Chapter 4.7 Mechanical connections		
	SWK-40/2	SWK-130/2
Fuel inlet and outlet	Union nut with a cutting ring for a pipe with an external diameter of 42 mm	G3"

## 6 Options

Please refer to chapter 5.4 which options are available for your filter.

### 6.1 Filter heating

Different heating coils are used as a heating element in the different filter sizes. The heating of the filter size SWK-40 is treated separately in one of the following chapters. Heating controls of SWK-40/MH are operating differently than models SWK-5/50/H, SWK-10/H and SWK-18/H.

#### 6.1.1 Heating system SWK-5/50, /10 and /18

##### Types of fuel pre heating systems

Operating voltage	Heating power rating
12 VDC	250 W
24 VDC	300 W
24 VDC	450 W

##### Heating connection

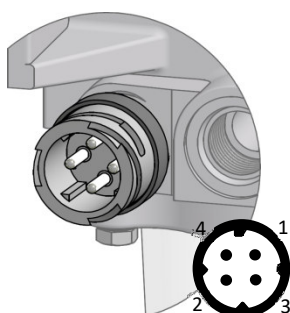

Connectors	
Pin 1	GND
Pin 2	Control terminal
Pin 3	GND (not used for all types)
Pin 4	VCC (has to be protected by electric fuse)

When fuel temperature is <5 °C, the control signal is connected to ground. At temperatures >10 °C, the signal is interrupted.

## External interconnection

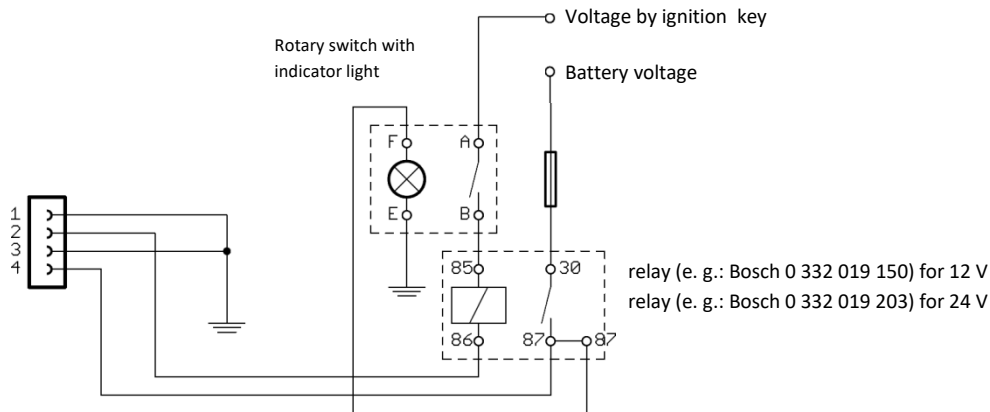

### 6.1.2 Fuel pre heating system SWK-40/MH or MHS

In the heated filter of the SWK-40 series, a heating power of 1400 W is fed into the fuel. The heating system is in a 230 V and a 440 VAC version available.



#### Attention

*The heater voltage must always be switched to the filter via an external contactor with sufficient breaking capacity. The heater voltage may only be switched on when the contact between pins C and D (Hummel connector: 3 and 4) of the control terminal is closed. This contact is closed at temperatures below 3 °C and interrupted at temperatures above 7 °C. In case of interruption between pins C and D (Hummel connector: 3 and 4) the heater voltage must be switched off immediately! Other switching states can cause damage to the heating filter.*

*If there are no errors in the filter, the contact between pins F and G (Hummel connector: 6 and 7) is closed and the contact between pins E and F is interrupted. In case of an error, the contact between pins F and G is interrupted and the contact between pins E and F is closed (Hummel connector: 5 and 6).*

## Control electronics

The control electronics are identical for all versions of the filters described here.

Operating voltage:	24 VDC
Maximum operating voltage:	36 VDC
Minimum operating voltage:	16 VDC
Power input:	< 10 W

## Types of heating systems

Operating voltage:	heater power rating
230 VAC (50 Hz/60 Hz):	1400 W
440 VAC (50 Hz/60 Hz):	1400 W

## Heating voltage connection

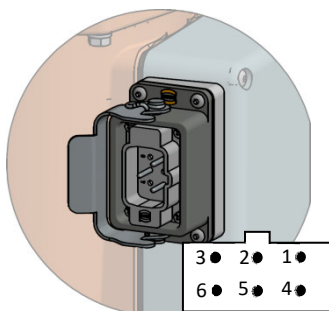

Connector: Harting

Pin 1 Heating voltage (see operating voltage from the heater)

Pin 3 Heating voltage (see operating voltage from the heater)

Pin 5 Protective conductor

## Separate protective earth terminal

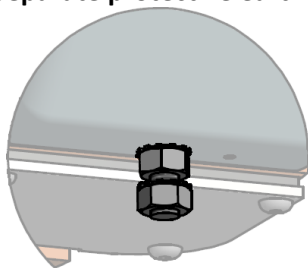

Old revision (stud M8)

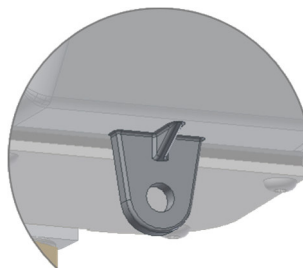

New revision (lug with hole 8,5 mm)

## Control connector (available with Cannon or Hummel connector)

Cannon:

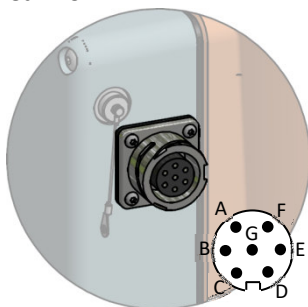

Hummel:

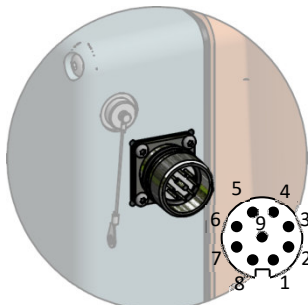

Connector

Cannon

Pin A

Pin B

Pin C

Pin D

Pin E

Pin F

Pin G

Connector

Hummel

Pin 1

Pin 2

Pin 3

Pin 4

Pin 5

Pin 6

Pin 7

Pin 8

Pin 9

24 VDC (for control electronics)

GND

24 VDC (for external main contactor)

Switching output for main contactor

Connection to 6 (F) in case of error

Medium changer connection (status)

Connection to 6 (F) if heater OK

Not used

Not used

## Simplified diagram of the heating system

# Willibrord Lösung Filterproduktion GmbH

W. Lösung Filterproduktion GmbH • Am Walzwerk 2 • 45527 Hattingen

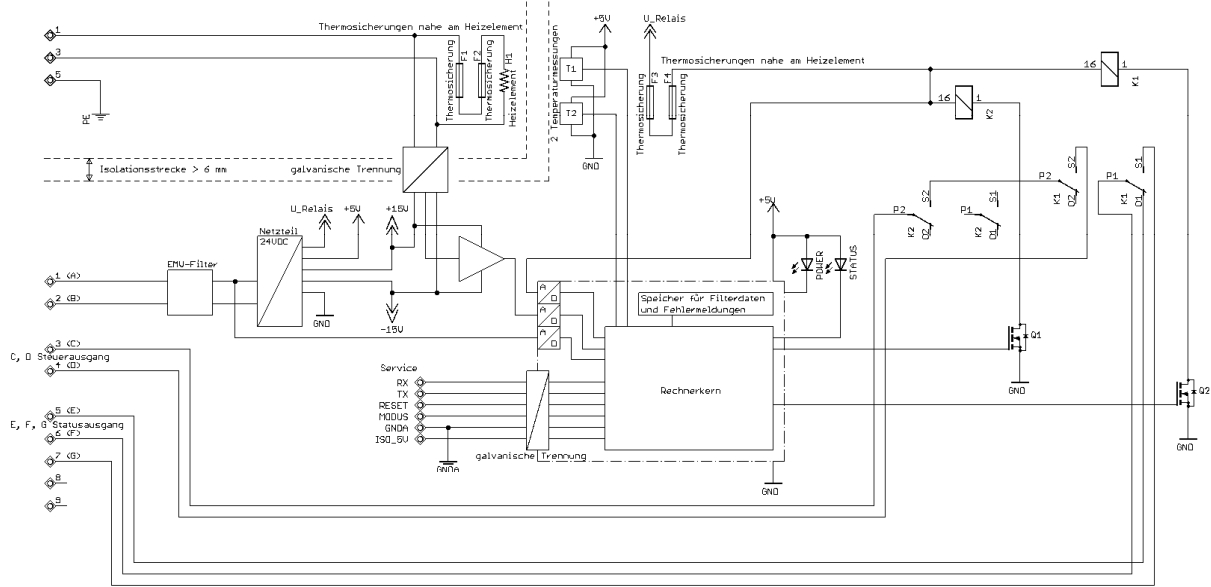

Connection example SWK-40/M/H: control unit

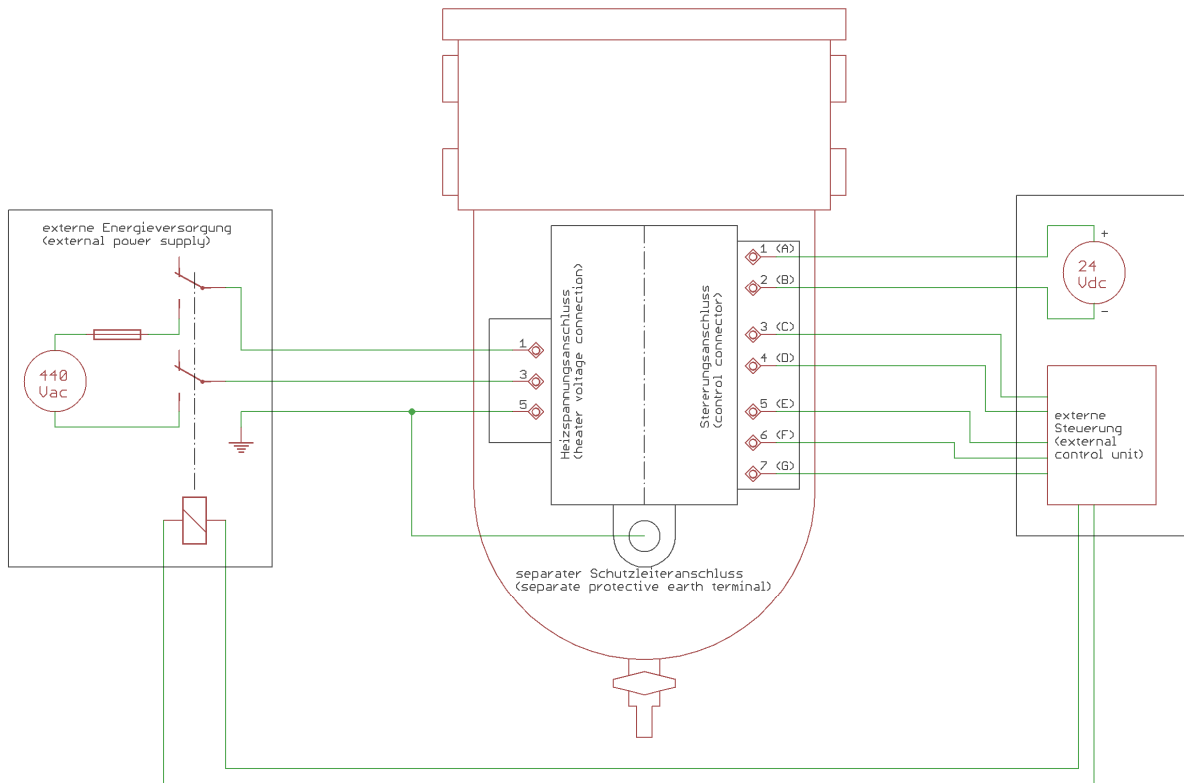

## Connection example SWK-40/M/H: simple contactor control

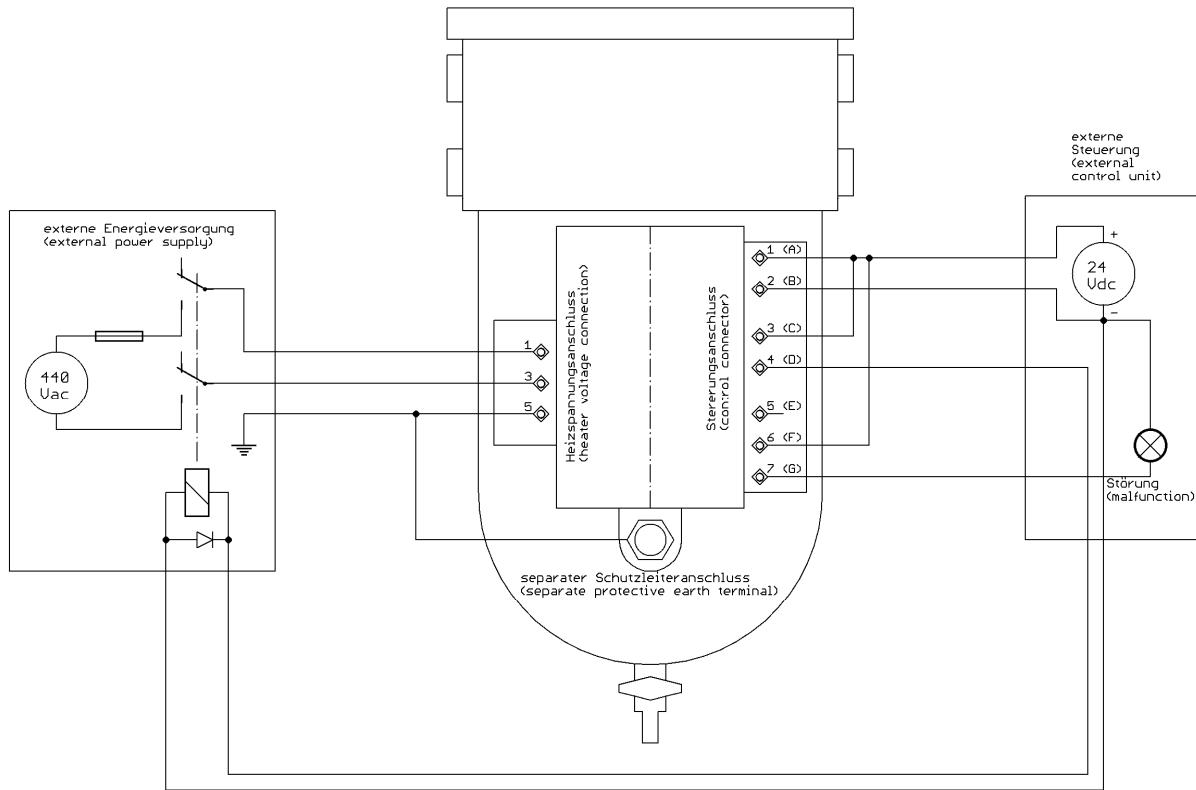

## 6.2 Water in fuel sensor (WIF)

Multiple WIF sensors are available either Bedia or SEPAR designed.

All sensor parts of the SEPAR-series are potential free. The detection of water is by capacitive measurement principle.

The exact technical specifications for water sensors can be found in a separate manual.

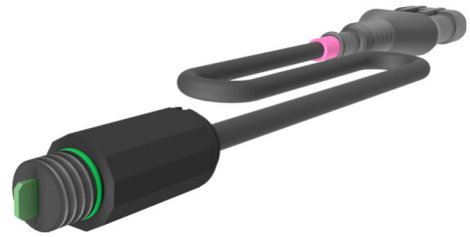

## 6.3 Differential pressure switch

The pressure switch is fitted in the fuel line at both the inlet and the outlet, and outputs an electrical signal when the differential pressure produced by the filter exceeds a calibrated value. The pressure switch is used as an indicator for a highly contaminated filter element.

## 6.4 Relative pressure switch

The relative pressure switch is fitted at the outlet port and outputs an electrical signal when the vacuum in the fuel line exceeds a calibrated value (measured against ambient air pressure). The pressure switch is used as an indicator for highly contaminated filter elements.

The function of the relative pressure switch is the same as the differential pressure switch. But the differential pressure switch is mounted at the inlet and the outlet port and can measure the differential pressure between inlet and outlet.

## 6.5 Vacuum gauge

The vacuum gauge is mounted in the outlet line of the filter and measures negative pressure (vacuum) downstream of the filter. You can use the vacuum gauge as a pollution indicator for the filter element.

To use the gauge as pollution filter you have to install an unused filter element to the filter. Launch the filter system and adjust the drag indicator to the preset value. We recommend to set a pressure rise of 200 mbar as alarm value.

## 6.6 Bowl

Plastic bowls (PA) are standard for SWK 2000/5, SWK 2000/10 and 2000/18. Aluminium bowls are available for those models as an option.

For models SWK 2000/40 and SWK 2000/130 only aluminium is available.

The advantage of transparent plastic bowl is that you can evaluate the water level and the degree of contamination of the collecting area without sensors.

The metal bowl is for harsher requirements and is resistant to broader range of temperatures and chemicals.



## 7 Assembly

### 7.1 Selection of mounting position

The SWK should be installed in an easily accessible location in the suction line of the fuel system between fuel tank and fuel pump. Any combination of inlet and outlet ports can be used.

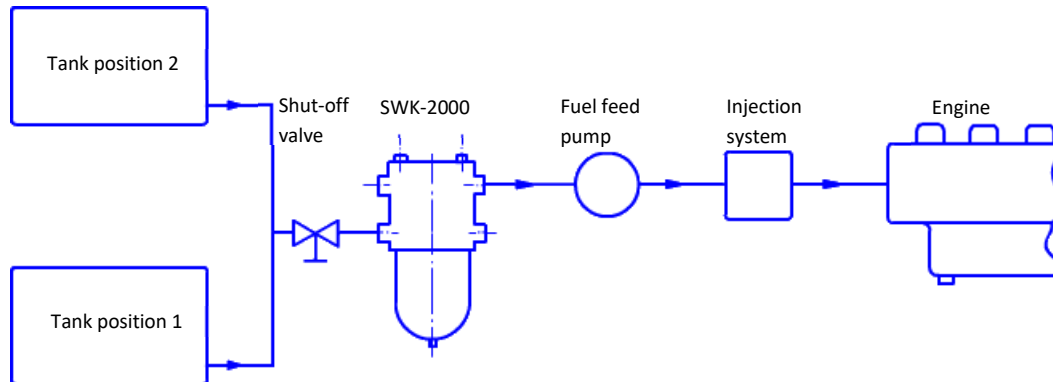

*A shut off valve is always recommended in between the tank and the filter. If the filter is positioned below the tank (position 2), there is always a slight pressure on the fuel inlet of the filter, which can facilitate the priming of the filter.*

**NOTE**



*When the filter is positioned higher than the tank (position 1), we recommend our hand priming pump HFP (s. chap. 11) to be mounted in the fuel line.*

**NOTE**

Please note that the filters have to be installed on an even surface..

When installing the filter sufficient space of at least 60 mm above the filter lid must be allowed.

Below the filter sufficient space must be left to either place a suitable container for draining bowl or to attach a hose directly to the drain valve to allow drainage of water out of the filter.

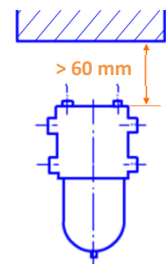

### 7.2 Filter installation

Install the filter with the back against a sufficiently stable and flat surface. Depending on the filter option the SWK offers two or four holes (s. chap. 4.1) for mounting the filter: The diameter of the mounting holes can be found in the technical data (s. chap. 4.2).

Subsequently, the fuel ports are connected. There are ports for inlet and outlet on either side of the filter housing. Matching fittings and adapters are a necessity please consult section 5.7 for port size.



Ensure in the design of the fuel lines that the radii of the curve segments are greater than 5-times pipe diameter in order to keep flow turbulence to a minimum.

### 7.3 Electrical connection

In its standard version, the SWK requires no electrical connections. Only when options with electrical connections are selected, such as filter heater, water sensor and pressure switch, the filter must be wired. For details see the appropriate subsections chapter 6.

### 7.4 Disassembly

Turn off the engine.

Set a suitable container under the drain valve.

Close shut off valves from tank. Open the bleed screw on the filter lid and then the drain valve. Let the filter run empty.

Remove the inlet and outlet pipes from the filter. Make sure that any still existing fuel can also flow into the provided container, to avoid pollution of the environment. Fuel leaking into the environment should be collected directly by an absorbent rag.

Loosen the screws on the rear panel and remove the filter carefully.

Dispose of the filter and the fuel and the materials needed (e. g. rag) in accordance with chapter 12.



## 8 Commissioning

After the filter has been installed in accordance with chapter 7, it can be put in operation.

1. Make sure that a filter element is inserted in the filter and check if all the openings of the filter are sealed.
2. Rotate the drain valve several times to ensure that no contamination blocks closing of the drain. Make sure that the drain valve is engaged in "closed" position.
3. Lay rags out to hold small amounts of fuel.
4. Open, if available, the shut off valve before the filter.
5. Loosen the bleed screw cautiously about 1-2 turns. Never turn the screw all the way out!
6. For priming of the fuel system use fuel priming pump.
7. Once the first small amounts of fuel come out of the bleed screw, tighten the screw again (observe the tightening torque, see chapter 9.1).
8. Turn hand priming pump in flow position
9. Start the engine.

## 9 Maintenance

For all maintenance works pay attention on providing suitable container under the SWK to catch spilled fuel and for proper disposal (s. chap. 12).

Basically, the housing of the Separ filter is maintenance free. The maintenance is restricted to removal of accumulated water in the bowl and to regular replacement of the filter element.

When screws of the filter are loosen and tightened again, please observe the tightening torques (s. chap. 9.1).

### 9.1 Tightening torques

The tightening torques listed to be strictly observed. Lid and bowl retainer ring screws have to be tightened in multiple turns and crosswise. Shown torques will result in no leakages of the filter and avoid damages to the filter.

Bolted assembly	Height	Tightening torque
Bleed screw	M6	4 Nm
Cover screws	M6 x 30	8 Nm
Bowl screws	M6 x 25	8 Nm

### 9.2 Drainage of water

If you find accumulated water at the bottom of the bowl, or the water sensor (optional) has triggered an alarm water has to be drained out of the bowl.



#### NOTE

*You should, if water has collected in the bowl, not wait to long with the drainage, as within a few days visible biomass might be found at the interface between water and diesel fuel. This defines itself as pollution to the bowl wall and can, if it dissolves, reduce the service life of the filter element.*

The following describes how the drainage must be performed. Make sure that during the operation no fuel can escape into the environment. Collect the fuel and dispose it properly (s. chap. 12).

1. Shut down the engine.
2. Close, if available, the shut off valve before the filter. In case of switchable filters switch lever to the other filter.
3. Open the bleed screw above the filter lod.
4. Open the drain valve. Water and dirt are flushed out of the bowl. Leave the drain valve open as long until cleaned fuel leaks. Collect drained fluids in a container and dispose as per local regulations.
5. Close the drain valve and the bleed screw (observe the tightening torque, s. chap. 9.1).

6. After the system has been primed, the engine can be restarted.

If the engine still shows power losses, replace the element.

## 9.2.1 Handling of the ball valve

### 9.2.1.1 Opening the yellow ball valve

Ball valve is closed.



Push knob.

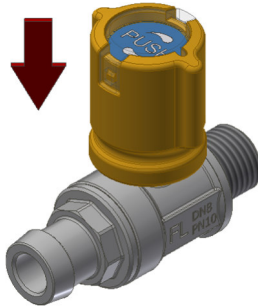

Turn knob counter-clockwise by a quarter turn.

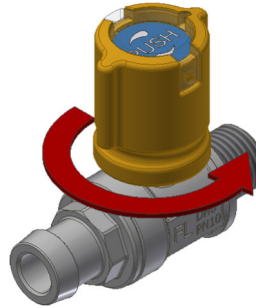

Ball valve is open.

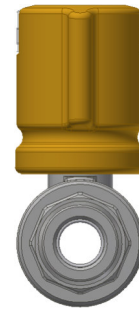
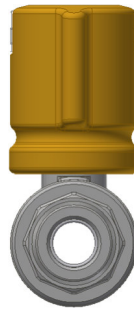
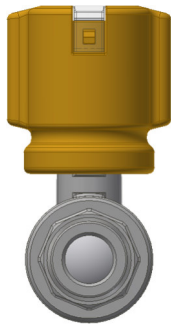

## 9.2.1.2 Closing the yellow ball valve

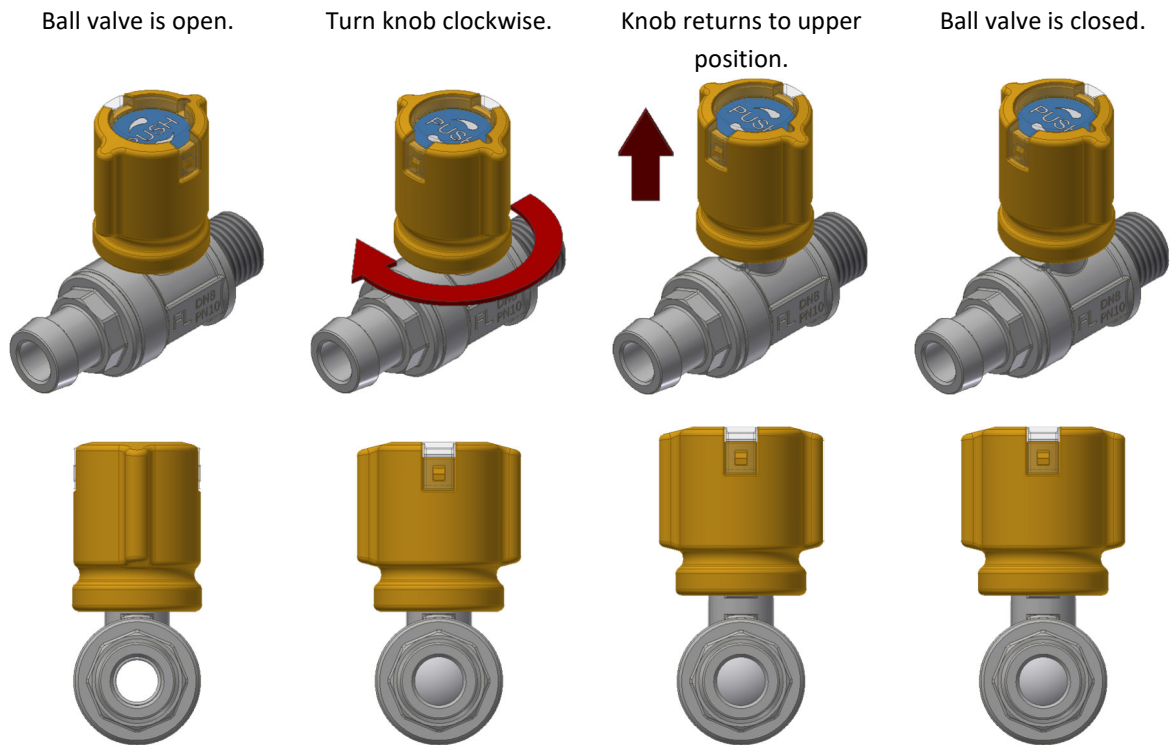

## 9.2.1.3 Opening the black ball valve

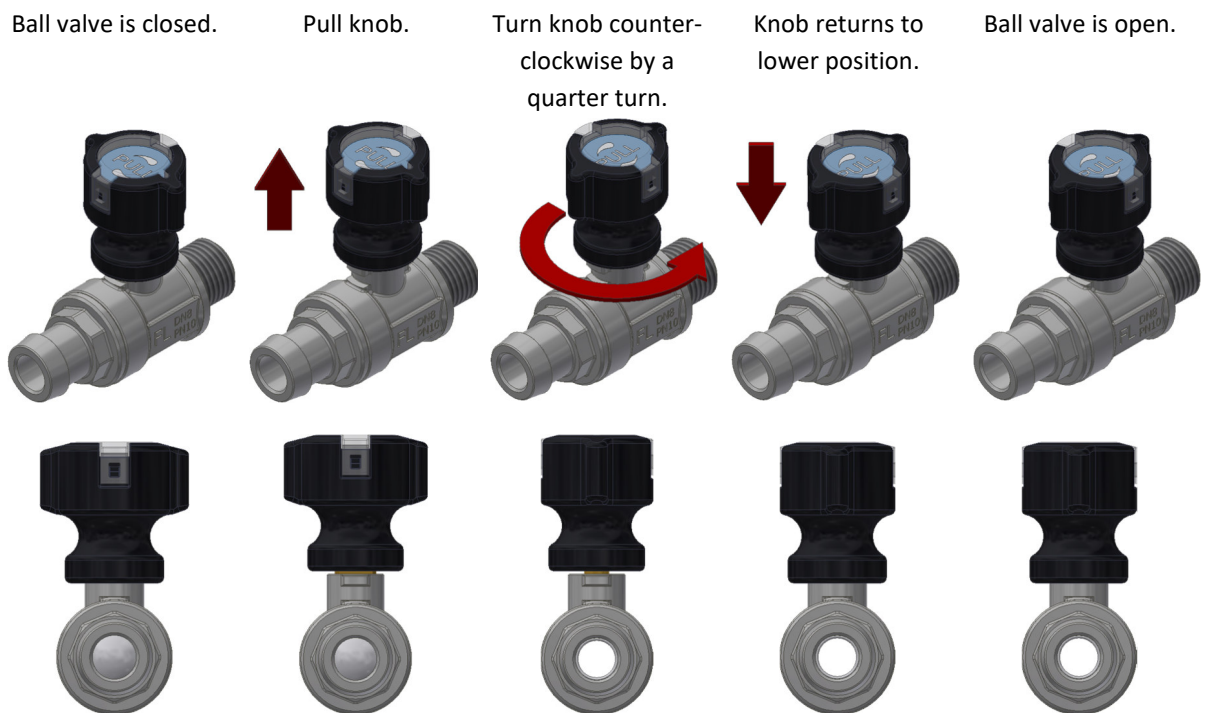

## 9.2.1.4 Closing the black ball valve

Ball valve is open.

Pull knob.

Turn knob  
clockwise by a  
quarter turn.

Knob returns to  
lower position.

Ball valve is closed.

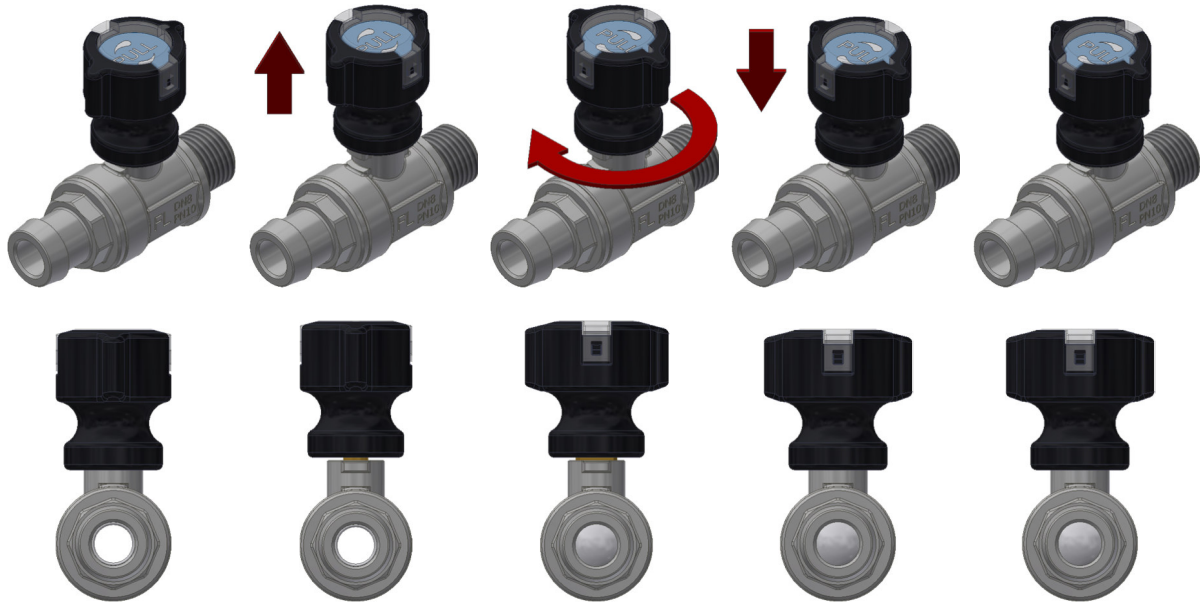

## 9.3 Back-flushing process

If the filter element is clogged by dirt particles and currently there is no way to replace the element, back-flushing can be used as an alternative. Hereby a part of the collected dirt again can be washed out. Depending on the degree of contamination the performance of the filter element can be restored.

1. Turn off the engine.
2. Open the bleed screw on the filter lid.
3. Place a container under the drain valve.
4. Open the drain valve by push or pull of the handle and turn it to a vertical position.
5. The clean fuel, which is located on the clean above the filter element, then flows back through the filter element and cleans the element from water droplets and fine dirt.
6. Drain as much fuel from the filter so that the dirt is flushed out of the bowl.
7. Rotate the drain valve several times to ensure that no contamination blocks closing of the drain. Make sure that the drain valve is engaged in "closed" position.
8. Close the drain valve.



9. Close the bleed screw.
10. Prime the fuel system.
11. The engine can be re-started again.

If the engine still continues to show power loss, repeat the process or replace the element (s. chap 0).



## 9.4 Element replacement

The filter element of the SWK should be changed if resistance exceeds engine manufacturer's specification, but at least once a year.

Replacement of the element:

1. Turn off the engine. In case of switchable filters switch lever to the other filter.
2. Close, if available, the shut off valve before the filter.
3. Open the bleed screw on the filter lid.
4. Open the drain valve. Water and dirt are flushed out of the bowl. Leave the drain valve open as long until cleaned fuel leaks. Collect liquids in a container and dispose according to the local regulations
5. Rotate the drain valve several times to ensure that no contamination blocks closing of the drain. Make sure that the drain valve is engaged in "closed" position.
6. Close the drain valve and the bleed screw (observe the tightening torque, s. chap. 9.1).
7. Loosen the screws on top of the filter lid in multiple turns and crosswise. Otherwise damage may be caused to the lid and / or housing.
8. Take off the lid. Remove the spring cassette. Lift the filter element at the bracket located at the element out of the filter. Dispose the filter element according to the requirements in chapter 12.
9. Insert the new filter element. It is important to make sure that the sealing surface is the bottom and the "Separ" logo represents the front.
10. Insert the spring cassette.
11. Replace if necessary the lid seal and hold the sealing surface of the filter housing and the lid seal clean. If a new gasket is not on hand, make sure that the seal is free from particles and slightly greased to ensure a perfect seal.
12. Put the lid back to its previous position and tighten the cover screws crosswise in multiple turns (observe the tightening torque, s. chap. 9.1) to prevent damage and leaks.
13. After the system has been primed, the engine can be restarted (s. chap. 8).

## 9.5 Cleaning



*Do not use any cleaning agents containing alcohol for cleaning! Alcohol changes the material properties of the plastic components used.*

Cleaning advice for transparent bowl:

- Use only clean diesel fuel for cleaning.
- Do not use hard or sharp-edged objects.
- Remove dirt completely with a soft cloth.

Cleaning advice for powder-coated components:

- Use only soft cloths. Avoid strong rubbing.
- In case of light soiling, clean with pure water -cold or lukewarm-, if necessary with small amounts of neutral or weakly alkaline detergents.
- Commercially available microfiber cloths are suitable for removing grease stains and fingerprints.
- In case of stubborn soiling, such as greasy or oily substances, cleaning can be carried out with aromatic-free benzene hydrocarbons (check beforehand on non-visible surfaces).
- Do not allow long exposure times of the cleaning agent. If necessary, repeat the cleaning process after some time. Rinse with clean, cold water immediately after cleaning.
- Do not use any scratching, abrasive agents.
- Do not use acidic or strongly alkaline cleaning and wetting agents.
- Do not use organic solvents containing esters, ketones (e.g. acetone), alcohols, aromatics, glycol ethers, halogenated hydrocarbons, thinners (e.g. nitro thinners) or similar.
- Surface and cleaning agent temperature < 25°C (No steam jet devices use).
- Do not use high-pressure cleaning equipment.

## 10 Repair

Actual spareparts list can be obtained from Willibrord Lösing Filtertechnik e. K. or your distributor. Please consider the recommendations/instructions given in chapter 7 for assembly and disassembly of the filter. Repairs that go beyond the replacement of parts must be carried out by W. Lösing Filterproduktion GmbH or an authorized company. W. Lösing Filterproduktion GmbH accepts no liability for any damage caused by unauthorized persons or organizations.

## 11 Accessories

A variety of accessories for the SEPAR filter can be obtained by Willibrord Lösing Filtertechnik e. K.filt or your distributor:

The hand priming pump HFP can also be installed in the fuel line and will ease the priming process. It is recommended to use the hand priming pump when the filter is situated higher than the fuel tank.

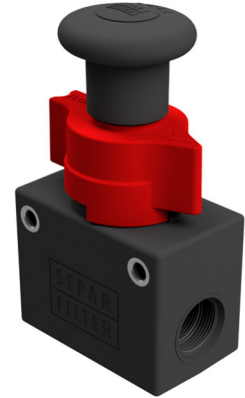

The water sensor WSA is available as an option (s. chap.0) and as a separate product. It triggers an alarm when the water level rises in the bowl and water should be drained. As a digital output signal are low-active and high-active.

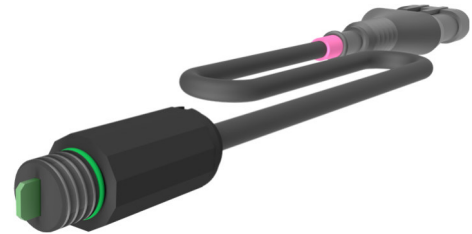



## 12 Disposal

Drain and remove the filter according to the instructions in chapter 7.4.

Disused fuel filters might contain harmful residues. As these spillfuel filters have to be disposed as per the local regulations.

The previous rendered diesel-water-dirt mixture belongs to the oil containing waste. With diesel fuel saturated absorbent, rags, etc. should be collected in non-combustible containers with self-closing lid.

Dispose any waste according to local regulations.

The specified waste code is only a recommendation. The waste producer is responsible for the concrete determination of the waste code.

## 13 Annex A: Special versions

The SWK-18 and SWK-40 filters are available in a fire-resistant version. These filters can be used in areas with increased requirements. A separate approval may be required for use in these areas.

The fire-resistant filters differ from the other SWK filters only by increased strength, weight and drain design. All other functions and system performances are identical in the respective filter class.

### 13.1 Drainage of water

If you find accumulated water at the bottom of the bowl, or the water sensor (optional) has triggered an alarm water has to be drained out of the bowl.



#### NOTE

*You should, if water has collected in the bowl, not wait too long with the drainage, as within a few days visible biomass might be found at the interface between water and diesel fuel. This defines itself as pollution to the bowl wall and can, if it dissolves, reduce the service life of the filter element.*

The following describes how the drainage must be performed. Make sure that during the operation no fuel can escape into the environment. Collect the fuel and dispose it properly (s. chap. 12).

1. Switch lever to the other filter.
2. Open the bleed screw above the filter lod.
3. Open the drain screw by turning it 3 times counterclockwise. Water and dirt are flushed out of the bowl. Leave the drain valve open as long until cleaned fuel leaks. Collect drained fluids in a container and dispose as per local regulations.
4. Close the drain screw by turning it clockwise until it securely closes the bowl. Then close the bleed screw (observe the tightening torque, s. chap. 9.1).
5. After the system has been primed, the engine can be restarted.

If the engine still shows power losses, replace the element.

## 13.2 Dimensions and weights

	SWK-18/U/FR	SWK-40/U/FR
Width	650 mm	810 mm
Hight	410 mm	491 mm
Depth	300 mm	370 mm
Weight	< 35 kg	< 65 kg
Mountig holes	4 x slotted holes (24 mm x 12 mm) Distance apart: 600 mm x 80 mm	4 x slotted holes (24 mm x 12 mm) Distance apart: 775 mm x 100 mm
All sizes and weights vary depending on the exact configuration of the filter assembly. For exact dimensions, refer to the specific drawing of your filter.		

## 13.3 Characteristics

	SWK-18/U/FR	SWK-40/U/FR
Flow performance	18 l/min	40 l/min
Complete interior volume per individual filter	3100 ± 90ml	7000 ± 200 ml
Water-holding capacity per individual filter	500 ± 30 ml	1500 ± 50 ml
Alarm on water quantity	300 ± 30 ml	1250 ± 50 ml
Max. allowable pressure	7 bar	4 bar
Water separation	> 99 % of free water <sup>5</sup>	
Available filter units	10 µm (coated cellulose paper) 30 µm (coated cellulose paper) 30 µm (stainless steel mesh) 60 µm (stainless steel mesh)	

## 14 Annex B: Specific drawings

Drawings for your personal filter configuration are compiled in a seperated document in case of request.

<sup>5</sup> The water separation was detected at W. Lösing Filterproduktion GmbH based on the DIN 4020 and the ISO-TS 16332.