

# LKF-Automotive

## Coalescence filter



### Quick Guide

The LKF coalescence filter reliably removes suspended particles and water from the fuel. Its low weight is achieved by the compact design and the use of lightweight materials.

#### Mechanical data

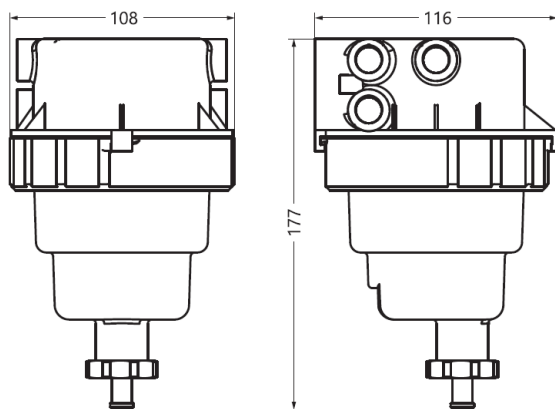

#### Performance data

mass:	< 0,5 kg
Ambient temperature	-40 °C ... 85 °C
Fixing points	2
Mounting bore	M8
Thread depth	12 mm
Max. screw length	18 mm
Tightening torque	5 Nm +/- 1 Nm
Media connectors	6
Internal thread	M14x1,5
Seal according	ISO 9974-1
Tightening torque	14 Nm +/- 1 Nm
Water sensor connector	
Internal thread	PG7
Tightening torque	Hand-tight
Operating pressure	
Continuous	-0,8 bar ... 5 bar
Short time (< 15 s)	< 6 bar
Pressure drop	< 50 mbar (at Vmax & 20 °C)
Volume flow (Vmax)	< 3 l/min
Separation process	Coalescence + hydrophobic barrier
Degree of water separation	> 95 % according ISO 16332
Available pore sizes	10 µm, 6 µm, 3 µm
Filter surface area	approx. 10 dm <sup>2</sup>
Water holding capacity	approx. 70 ml
Water alarm at (optional)	approx. 60 ml

#### Mechanical connections

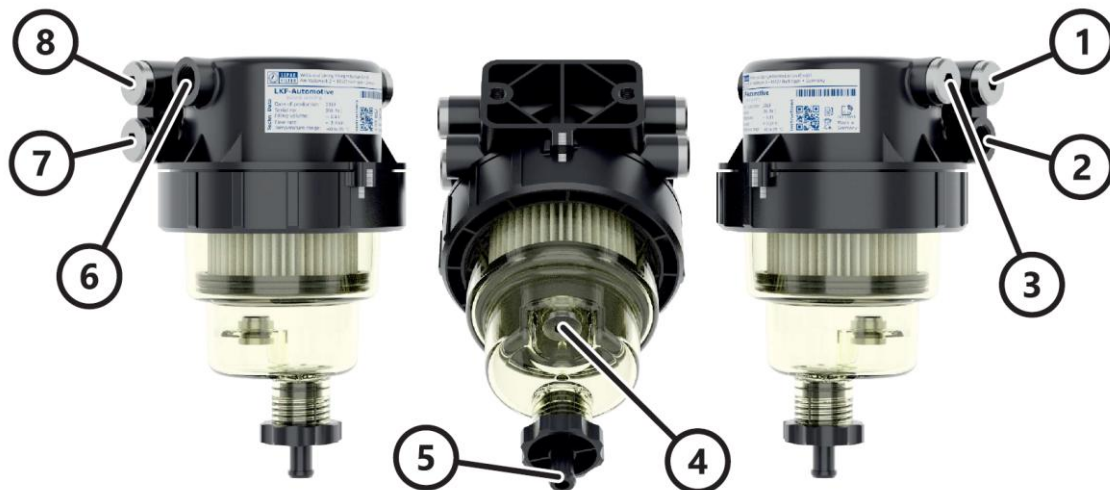

- |                        |                                    |                         |                        |
|------------------------|------------------------------------|-------------------------|------------------------|
| 1 For future expansion | 3 Media outlet, right              | 5 Nozzle for Drain hose | 7 Media inlet, left    |
| 2 Media inlet, right   | 4 Screw-in thread for water sensor | 6 Media outlet, left    | 8 For future expansion |

## Mounting

The filter is fixed with two metric screws, which are screwed into the mounting flange.

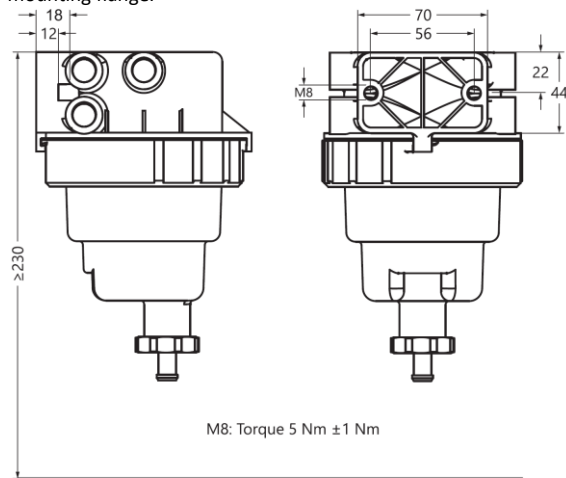

- ▶ The filter is undamaged and the package content is complete.
  - ▶ A clearance height of at least 230 mm is existing at the mounting location.
  - ▶ The filter can be mounted so that sufficient space remains under the drain nozzle for the connection of the drain hose.
  - ▶ The mounting flange does not protrude over the mounting surface.
1. Drill two holes at correct separation distance from each other and horizontal to each other.
  2. Deburr bores.
  3. Insert both screws through from the rear side of the mounting surface and screw hand-tight into the mounting flange of the filter.
  4. Align filter so that its axis is vertical.
  5. Fix filter and tighten both screws with the admissible torque.
- = The filter is mounted.

## Connection

The media connectors are designed as tapped holes according to ISO 9974-1. Sealing plugs or connectors, which correspond to ISO 9974-2, can be screwed into them.

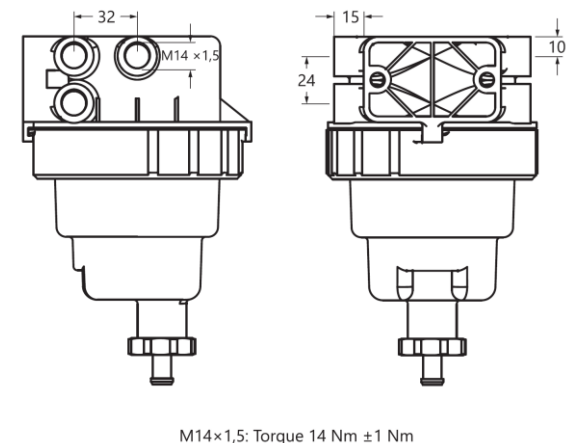

Media inlet:	Connection for the fuel pipe from the deepest point of the tank.
Media outlet:	Connection for the fuel pipe to the injection system.
Nozzle for drain hose:	For simpler drainage of the filter, a hose which is suitable for the medium can be slid on.
Screw-in thread for water sensor:	A water sensor which is available as an accessory can be screwed into this screw tap, where the sensor must be evaluated by additional electronics. This allows a message to be generated when the filter needs to be drained.

## Initial commissioning



Before initial start-up, make sure that all 6 lateral connections and the water sensor connection (bottom) are tightly closed. In addition, the water drain must be screwed shut and the container must be completely closed by means of a bayonet ring (white closure indicator on head and ring are exactly on top of each other).

## Spare parts

REF	Description
06 3802	LKF-Automotive with filter element 3µm
06 3803	LKF-Automotive with filter element 6 µm
06 3800	LKF-Automotive with filter element 10 µm
06 3744	filter element 3 µm
06 3745	filter element 6 µm
06 3710	filter element 10 µm
06 3746	Seal set (2x O-ring for drain valve, 1x O-ring for container)
06 3748	container with drain valve and seal set
06 3664	Bayonet ring
06 1558	Plug PG7 with O-ring
06 3681	Plug M14x1,5 with profile seal

## Documentation

Special features of options for this product can be found in the operating manual.

 In Ihrer Sprache auf  
 In your language at



<https://www.separ.de/lkf-a>